

AQUEA

BUBBLER+

INSTALLATION GUIDE

(PART NO. 532-250)

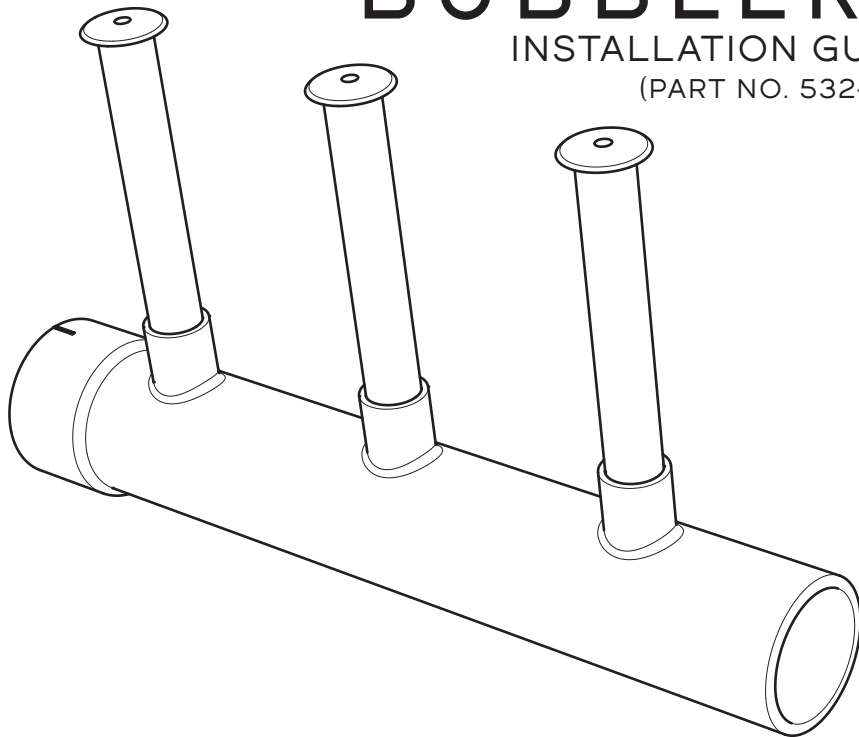

NOTE:

1. READ THIS DOCUMENT PRIOR TO INSTALLATION. IMPROPER INSTALLATION WILL VOID WARRANTY.
2. PRODUCT MUST BE INSTALLED & SERVICED BY A QUALIFIED PROFESSIONAL.
3. MANIFOLD (PART 532-420) MANUFACTURED FROM ABS. INSTALLER MUST CONFIRM JOINTING COMPOUND IS COMPATIBLE WITH ABS BEFORE USE.
4. INSTALLER TO ENSURE INSTALLATION MEETS ALL APPLICABLE ENGINEERING & REGULATORY REQUIREMENTS.
5. THIS MANUAL CONTAINS IMPORTANT INFORMATION AND SHOULD BE STORED IN A SAFE PLACE AFTER INSTALLATION.

AQUEA™ - 17 DIANA DRIVE, BLACKBURN NORTH, VICTORIA 3130.

PRODUCT SUPPORT - HELLO@AQUEA.COM.AU PHONE - 0481 875 870

KIT CONTENTS

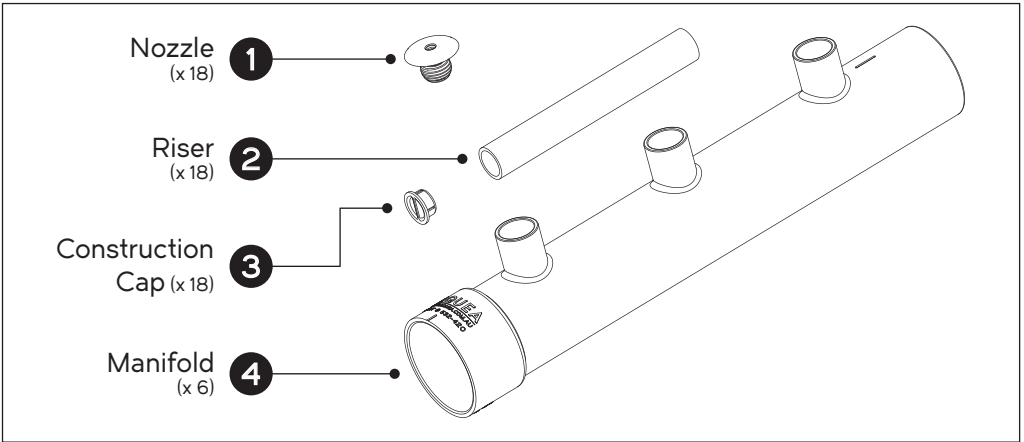

TYPICAL INSTALLATION

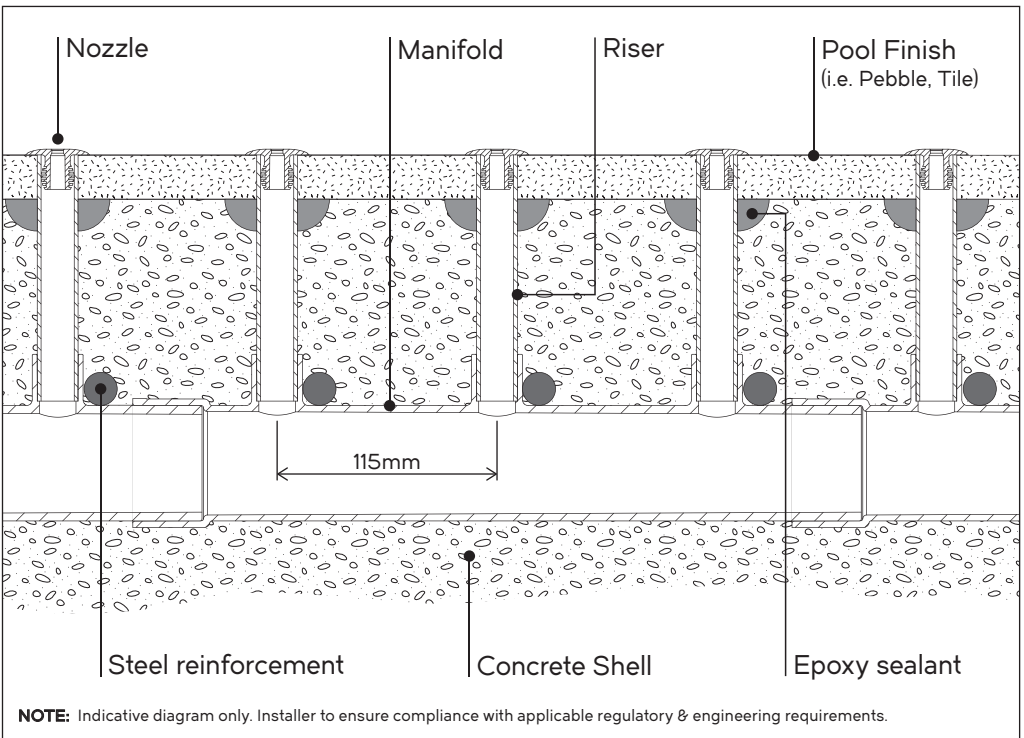

Registered Design. Specifications subject to change without notice.

Ref: 532-802-01

AQUEA™ is a trademark of Vantage Products Pty. Ltd.

INSTALLATION TIPS

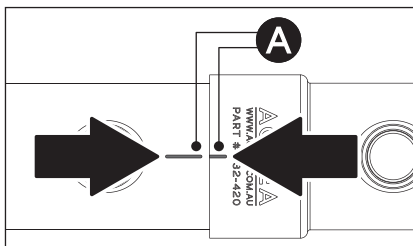

Align marks (A) when joining Manifolds to ensure Risers are correctly aligned.

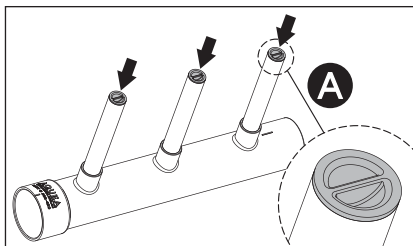

Keep Construction Caps in Risers (A) so Manifold remains clear of debris during construction.

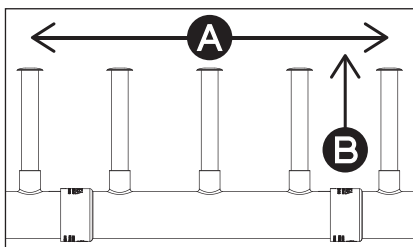

Ensure Manifold and Risers are secured level (A) and plumb (B) as necessary to suit installation site requirements.

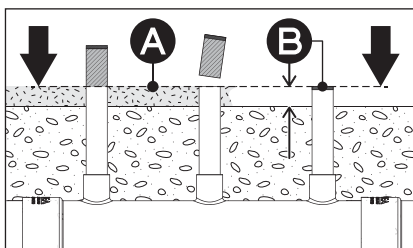

(A) **Tile:** Trim Risers flush when tiling is complete.

(B) **Pebble:** Trim Risers, allowing for pebble thickness. Insert Caps before pebbling.

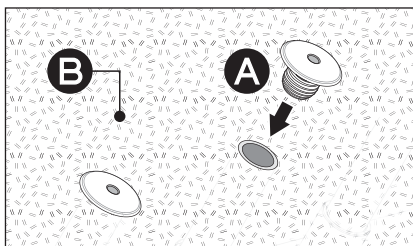

Insert Nozzles (A) into Risers firmly against interior finish (B). **ADHESIVE OR SILICONE IS NOT REQUIRED.**

⚠ PLEASE NOTE:

- BUBBLER+ air-loops can be installed in closed-loop, straight-line and horseshoe configurations.
- Apply full & even coverage of ABS-compatible solvent cement to ensure strong and water-tight connections.
- BUBBLER+ feed-line can be located anywhere within the nozzle array. Scan QR code below for more information.
- Install and connect blower in accordance with manufacturer instructions and safety requirements.
- Maximum recommended nozzles & depths*:

Water Depth	Nozzles (max)
Up to 500mm	36
Up to 1000mm	27
Over 1000mm	Note 6

- Builder / Installer to determine maximum nozzles according to specific site requirements and water depth.
- Contact your pool pre-plumb stockist for recommended air equipment to suit your project.

* Figures stated based on testing with Spa-King 1100W "Peacemaker" blower.



Scan for more information and BUBBLER+ technical specifications.

The contents of this manual are the exclusive copyright of AQUEA™ and may not be reproduced without written permission. © 2021

Whilst every care was taken in preparation of this document, AQUEA™ accepts no responsibility for the accuracy of the information supplied.

WARRANTY POLICY

AQUEA (a division of Vantage Products Pty. Ltd.) warrants that, subject to the exclusions and limitations below, its products will be free from defects in materials and workmanship for a minimum period of 12 MONTHS from the date of purchase. All warranty periods commence on the date of purchase by the customer and are only valid in original country of purchase. The provisions of this warranty are not transferable.

If a defect appears in any Product supplied by AQUEA before the end of the Warranty Period due solely to defective materials or workmanship, AQUEA will in its sole discretion, and subject to these terms and conditions, either:

- a) repair the Product or the defective part of the Product free of charge; or
- b) have the Product or the defective part of the Product repaired by a qualified repairer free of charge; or
- c) replace the Product.

AQUEA at its sole discretion may replace defective parts of the Products with parts and components of similar quality, grade and composition where an identical part or component is not available. Refurbished parts may be used to repair the Products.

All repairs are to be carried out by AQUEA or its authorised repairer only. This warranty does not cover any costs related to travel, removal or re-installation associated with repair or replacement of the Product.

TO MAKE A WARRANTY CLAIM

To claim under this warranty the customer should immediately cease use of the Product once alleged defect is identified, and contact AQUEA within 30 days.

To make a claim the customer must:

1. Provide the following information:

- (a) proof of purchase disclosing date and place of purchase;
- (b) full details of the alleged defect; and
- (c) any other appropriate documentation.

2. The customer must make the Product or site available to AQUEA or its authorised repair agent for inspection and testing. If such inspection and testing finds no defect in the Product, the customer must pay AQUEA's usual costs of service work and testing.

3. The customer agrees to pay AQUEA's usual charges (including any service fee) for any goods or services provided by AQUEA not covered by this product warranty.

4. The customer is responsible for the cost of transport and all insurance of the Product to and from AQUEA or its authorised repair agent.

WARRANTY CONDITIONS

This warranty only applies where the following conditions are met:

1. The customer complies with the following general maintenance requirements:

- (a) The Product is maintained free from general debris or foreign matter.
- (b) The Product is maintained and serviced regularly (at least every 12 months) by a suitably qualified professional.
- (c) Where applicable, the Product is replaced at specified intervals as outlined in product literature by AQUEA.

2. Where applicable, Product has been used in pool or spa water which:

- (a) is maintained within a pH range of 7.2-7.6, and chemically balanced as per accepted industry standards.
- (b) is regularly (at least once a month) treated with a sanitising system in compliance with applicable regulatory recommendations or regulations.
- (c) has not exceeded 40 degrees Celsius in temperature.
- (d) has not been exposed to freezing conditions.

WARRANTY EXCLUSIONS

This warranty will not apply where:

- (a) the Product has not been installed in accordance with the installation instructions provided with the Product, any statutory requirements and these terms and conditions;
- (b) the Product has not been installed by a suitably qualified professional trained in the installation and operation of such products with more than 12 months industry experience;
- (c) a failure to observe and comply with the instructions supplied with product for the proper use, service or maintenance of the Product has occurred;
- (d) the Product has been used for a purpose other than that for which it was designed and manufactured;
- (e) removal or installation of the Product has contributed to, or resulted in, the defect or damage;
- (f) the Product has been repaired, altered or modified by someone other than AQUEA or its authorised agent;
- (g) substitute or replacement parts not provided by AQUEA have been used;
- (h) the defect has arisen due to abuse, misuse, neglect, or accident;
- (i) the Product has been subject to abnormal conditions, including environment, temperature, water, fire or other acts of nature;
- (j) the Product has been subject to abnormal corrosive conditions or abrasive chemicals;
- (k) the defect is the result of corrosion or normal wear and tear;
- (l) the defect is the result of insect and/or vermin infestation;
- (m) concrete, cement, render, pebbles or other pool surface finishes contribute to the defect, or inhibit proper function of the Product;
- (n) the damage occurred in transit;
- (o) after testing and inspection AQUEA cannot establish any fault in the Product;
- (p) the Product has been used in a commercial application;
- (q) the Product has not been supplied by AQUEA;
- (r) the defect is related to any cause other than a defect in the materials or workmanship of the Product.

LIMITATIONS

AQUEA makes no express warranties or representations other than set out in this warranty.

Except to the extent required by the Australian Consumer Law, the repair or replacement of the Product or part of the Product is the absolute limit of AQUEA's liability under this express warranty.

To the extent permitted by law, AQUEA will not be liable for:

- (a) Damage to any other property caused by defect in the Product.
- (b) Any indirect, special or consequential loss arising from or related to defects in the Product, including, but not limited to, loss of time, loss of use of the product, loss of business opportunity, loss of profits, loss of revenue, loss of goodwill, or inconvenience.
- (c) Any other damage as a result of weather or natural disaster.
- (d) Any claim against the customer by other parties.

Our goods come with guarantees that cannot be excluded under the Australian Consumer Law. You are entitled to a replacement or refund for a major failure and for compensation for any other reasonably foreseeable loss or damage. You are also entitled to have the goods repaired or replaced if the goods fail to be of acceptable quality and the failure does not amount to a major failure.

The benefits of this warranty are in addition to any rights and remedies imposed by Australian State and Federal legislation that cannot be excluded. Nothing in this warranty is to be interpreted as excluding, restricting or modifying any State or Federal legislation applicable to the supply of goods and services which cannot be excluded, restricted or modified.

CONTACT

For warranty claims visit www.aquea.com.au or contact AQUEA using details overleaf.

(Policy Revision 03)